

Mr Bounce Trampoline

CONTENTS:

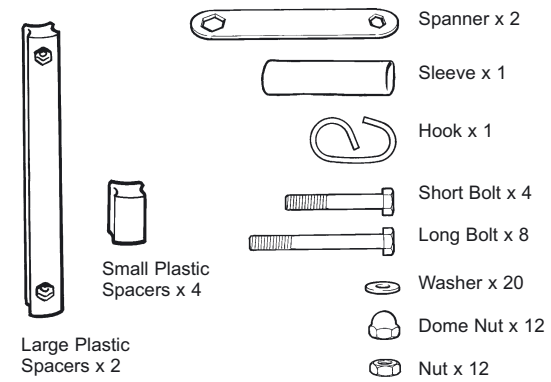
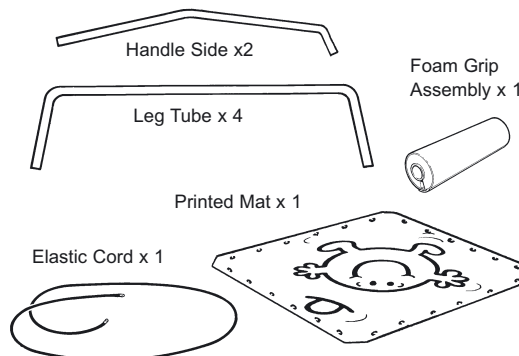

SAFETY NOTICE

Caution and care must be taken in the unpacking and assembly of this product. Due to small parts and packaging materials. Adult assembly is required.

Adult supervision of this product is required at all times. Do not leave a child unattended.

Outdoor use - position away from water on flat firm ground, ideally grass. Never position on or near to hard surfaces such as patios or driveways, or close to buildings.

Ensure area under and around trampoline is clear of any toys/obstacles that may cause injury.

Indoor use - position so that there is sufficient ceiling height. Never position immediately below light fittings.

Recommended age for this trampoline is 3-8 years. Maximum weight limit 30Kg.

This Trampoline is designed for one user only. Do not let more than one child use this product at the same time.

Users should not wear clothing that could catch or snag on the product (eg loose clothing, cords, shoulder bags, jewellery.)

Users should stand or bounce as near to the centre of the mat as possible. Bouncing or standing near the edge of the trampoline could cause the frame to tip over.

Do not allow small children to wander into the play area whilst the trampoline is in use.

Do not allow small children to crawl or hide under the trampoline.

Discontinue use if any breakage is found. Failure to do this may result in injury.

All hard-soled foot-ware must be removed before use to avoid damaging the printed mat surface.

Not suitable for children under 3 years. This toy contains small parts which may cause choking.

Please retain this leaflet for reference to the manufacturer

Carefully made in China to European Safety Standard

CE This mark denotes compliance with the standards laid down by the EC (European Community).

DISTRIBUTED BY



MV SPORTS & LEISURE LTD

35 Tameside Drive • Castle Bromwich

Birmingham • B35 7AG • UK

Email: info@mvsports.com

www.mvsports.com

THIS PRODUCT IS WEIGHT TESTED

Under no circumstances must this product be used by an adult or anyone over 30kgs.

IMPORTANT:

In the interest of your child's safety it is important that you read both the safety notice and the assembly instructions below carefully, before allowing your child to use this piece of apparatus.

NB Before Assembly

1. Check all components are present.
2. Trampoline must be assembled on a flat surface.
3. It is recommended that the mat is threaded to the frame by two adults.

- 1 Line the holes in 2 legs together so that the legs form an 'L' shape. Insert a Large Spacer making sure that the two hexagonal recesses are facing out (as shown). Bolt together until finger tight using: Long Bolts washers and nuts (do not add dome nuts at this stage). Bolt on the remaining two legs so that a square frame is formed. Ensure that front pair of legs are formed using the Large Spacers and the back pair of legs using the two Small Spacers on each leg. (as illustrated).
N.B Ensure that the four legs are level and all in contact with the ground.

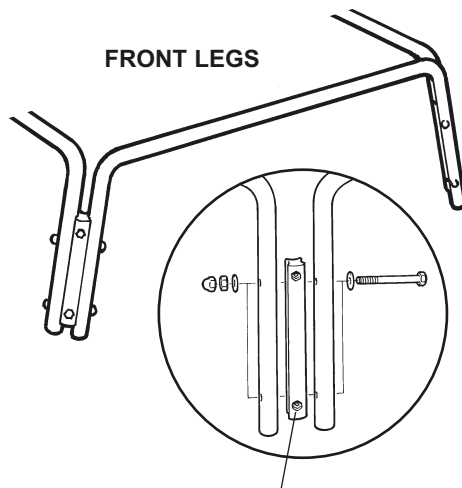

FRONT LEGS

Hexagonal recess

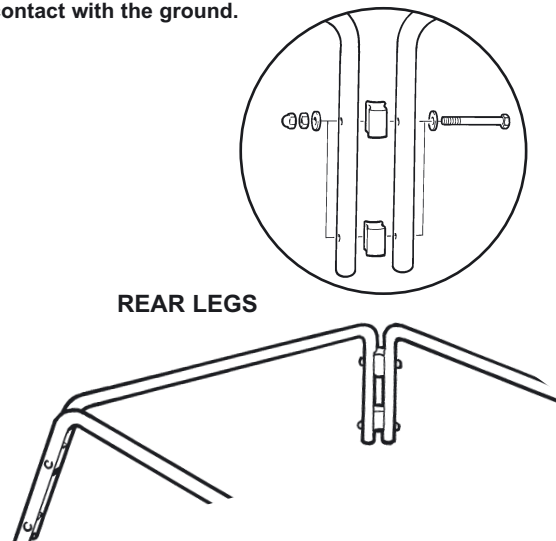

REAR LEGS

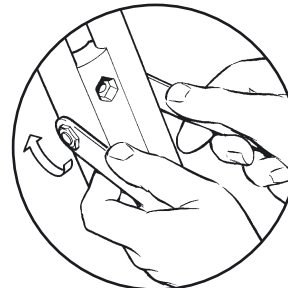

Tighten all of the nuts using the two spanners provided as shown, then add and tighten 8 Dome nuts using the spanners provided.

- 2 Push Handle Side tubes firmly into the Handle Top Tube as shown. We recommend that the cover seam and split in the foam grip are together and twisted around to the underside of the handle.

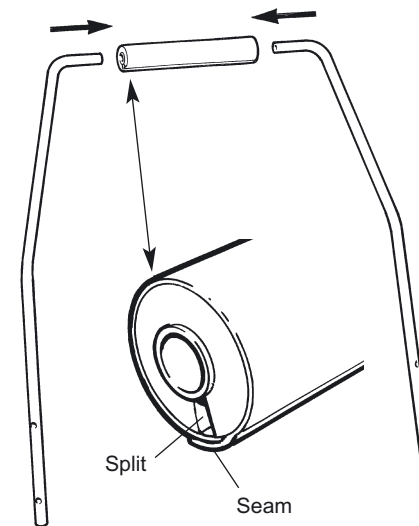

Split

Seam

CUSTOMER HELPLINE

We make every effort to ensure that this product reaches you in satisfactory condition.

However if you have any queries, need assistance, or find this product defective, please call our Customer Helpline:

0870 8404255 (UK ONLY)

3

Insert the Handle assembly inside the square frame and line up the holes in the Handle sides with the two centre holes in the Spacers.

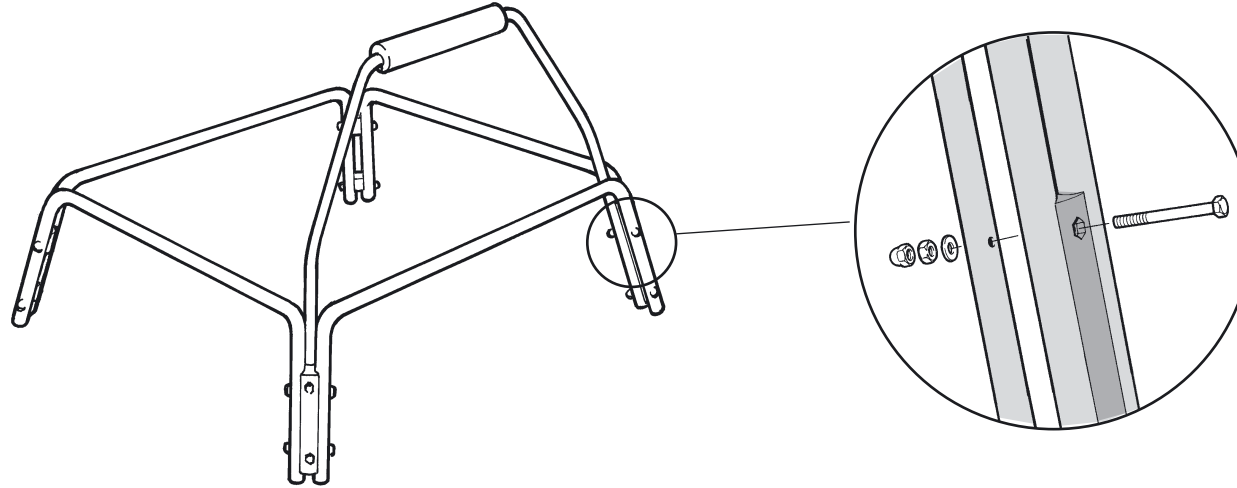

Push the short bolts through the spacers and the Handle until the bolt heads are within the spacer recesses. Add the remaining washers & nuts, tighten using the spanners provided, then add and tighten the Dome nuts

4 Threading the Mat

Starting at one corner thread the elastic cord around the legs and up through the two mat eyelets as shown. Ensure that both the lengths of elastic cord are equal in length.

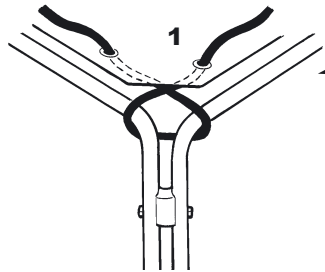

1. Threading First Corner
Start threading the elastic cord to the frame as shown. Ensure that the elastic cord is as tight as possible whilst threading.

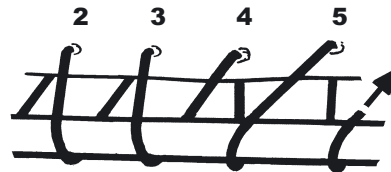

2. Threading Middle change-over
N.B when eyelet 3 is reached change the threading pattern. Take the elastic cord around the leg tube as before, but now push the elastic cord **down** through eyelet 4 and around the leg tube (as shown) Repeat until the side is threaded.

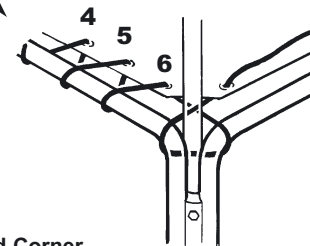

3. Threading Second Corner
When eyelet 6 is reached thread the elastic cord around the corner as shown and repeat the above until the remaining three sides are threaded. (Don't worry if the mat is not central with the frame at this point).

5

When the last eyelets have been threaded by both ends of the elastic cord (should be at one corner) push the flexible plastic sleeve over one end and thread the metal hook through the eyelet in the elastic cord (as shown). Then hook on the other side of the elastic cord and cover the joint with the plastic sleeve.

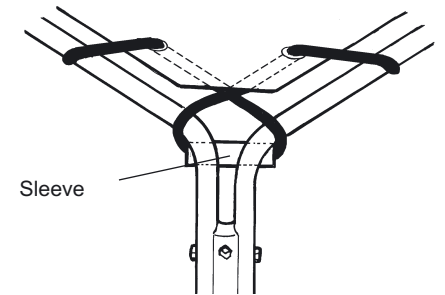
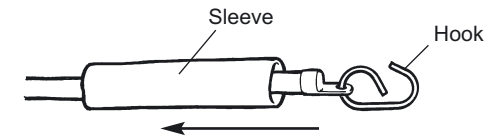

NOTE: The mat will automatically centre in the frame when in use.