

16" Cruiser Bike

Important owner's information

Please read this before allowing your child to ride the bicycle.

CORRECT BICYCLE SIZE

Make sure the bicycle you have bought is the correct size for the child. The minimum crotch measurement of the rider, with feet flat on the ground, should be 1" (25mm) more than the height of the bike.

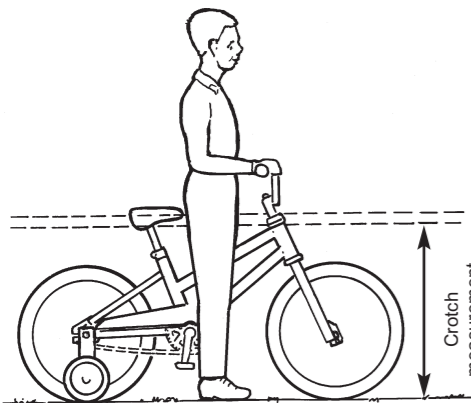

BICYCLE SET-UP

It is essential that, before moving off, the rider is comfortably seated on the bicycle and not stretching forward to reach the handlebars. Re-check the instructions given for the installation of the saddle.

FOR YOUR CHILD'S SAFETY

Recheck that all screws, nuts and bolts are firmly tightened. Make sure that your child is capable of riding this bicycle. Do not allow your child to ride without supervision.

BASIC MAINTENANCE

To adjust the tension of the chain drive, loosen the two rear wheel retaining nuts and move the back wheel either forwards or backwards to adjust tension. Re-tighten nuts once correct tension is achieved.

Brake blocks must be checked by an adult at regular intervals. It is recommended that the brake blocks are replaced if they become less than 3mm on the shortest side.

Lubricate moving parts with light machine oil at regular intervals or when necessary.

Any wear on tyres must be checked by an adult. Please note helpline number for replacement parts.

RECOMMENDED TORQUE TOLERANCES

Handlebar clamp	15 nm
Seat Post	15 nm
Wheels	20 nm

TYRE PRESSURE

Tyre pressure 30-35 psi
Ensure tyres are firm but do not overinflate

Please retain this leaflet for reference to the manufacturer.
Made in China to European Safety Standards.

Conforms to ISO8098

CUSTOMER HELPLINE

We make every effort to ensure that this product reaches you in satisfactory condition.

However if you have any queries, need assistance, or find this product defective, please call our Customer Helpline:

0870 8404255 (UK ONLY)

DISTRIBUTED BY



MV SPORTS & LEISURE LTD

35 Tameside Drive • Castle Bromwich • Birmingham • B35 7AG • UK
Email: info@mvsports.com • www.mvsports.com

TOOLS REQUIRED

NOT SUPPLIED

Spanner sizes:
10mm for brakes
13mm for saddle
15mm for pedals

Screwdriver

Pliers

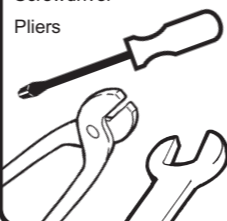

CONTENTS:

- 1 Frame and handlebar assembly
- 2 Front wheel
- 3 Saddle, pillar and backrest assembly
- 4 Pedals (pair)
- 5 Backrest securing screw (x2)
- 6 Backrest securing washer (x2)

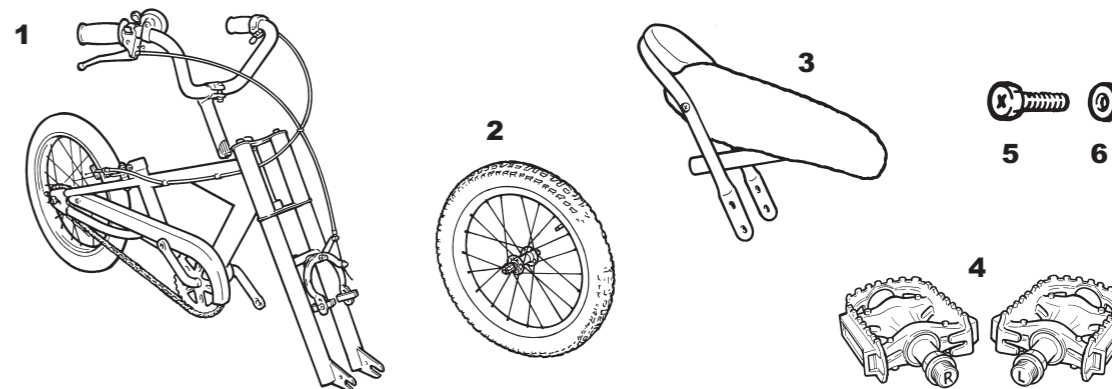

This bicycle is to be assembled by an adult

Check the contents and only remove the protective packaging from each item as and when it is to be fitted

Please keep the packaging until you have completely assembled the bicycle.

FITTING THE PEDALS

NOTE: The pedals are identified as right hand or left hand by an 'R' or 'L' on the spindle end.

- 1 Screw the pedal marked 'R' clockwise into the right hand chain wheel crank (side with chainguard) and tighten securely.
- 2 Screw the pedal marked 'L' anti-clockwise into left hand crank and tighten securely.

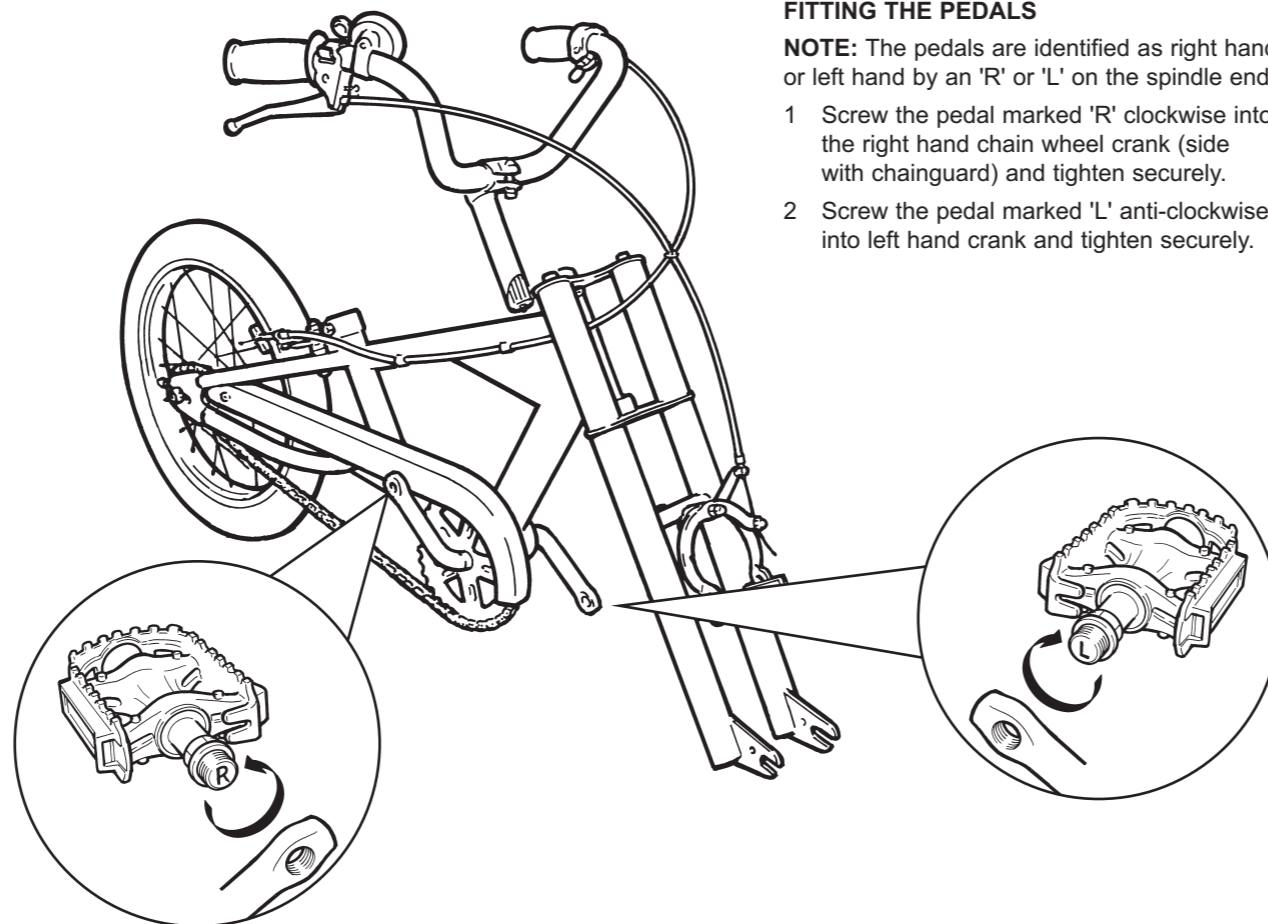

FITTING THE HANDLEBARS

- 1 Slide the handlebar pillar into the frame head up to the minimum insertion mark.
- 2 Align the handlebar with the front forks and tighten the securing bolt on the top of the handlebar pillar.

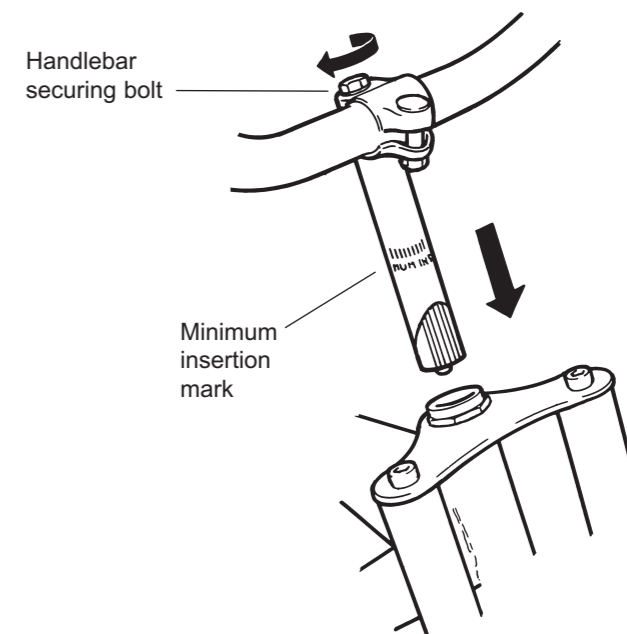

FITTING THE FRONT WHEEL

- 1 Loosen the front wheel nuts sufficiently to allow the tabbed locating washers to fit outside the fork end.
- 2 Insert the front wheel into the front forks, sliding the wheelspindle into the slots in the fork end.
- 3 Ensure that the locating washer tabs are inserted into the holes in the fork end.
- 4 Check that the wheel rim is central between the forks and tighten the wheel nuts.

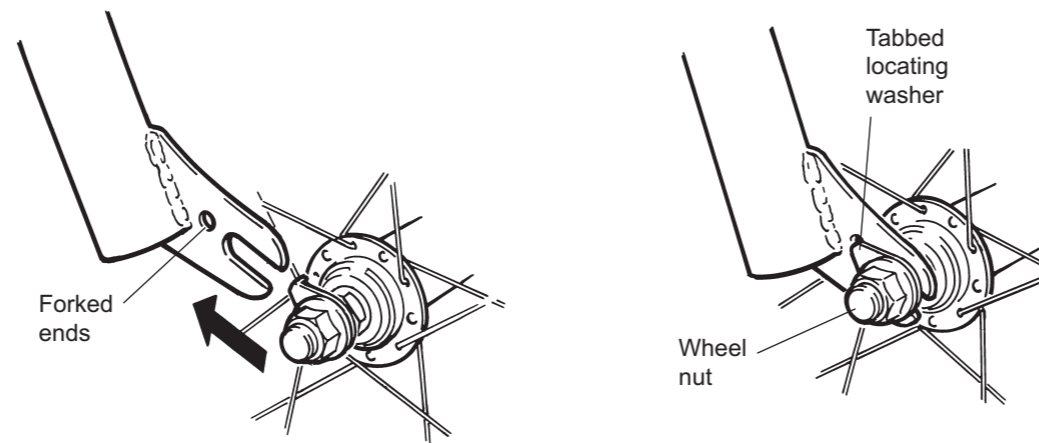

ADJUSTING THE BRAKE LEVER POSITION

- 1 If necessary loosen the brake lever clamp screws, reposition the brake levers to suit the rider and retighten the clamp screws.

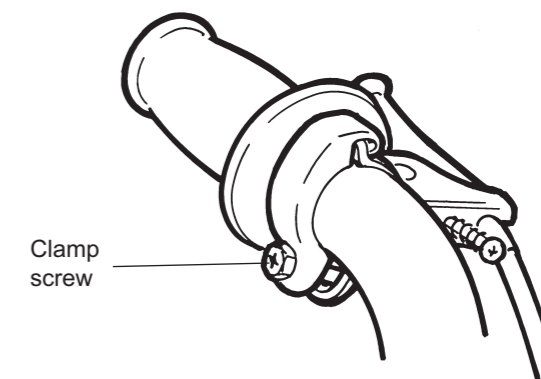

FITTING THE SADDLE ASSEMBLY

- 1 Insert the saddle pillar into the down tube of the frame assembly as far as the minimum insertion mark.
- 2 Position the backrest frame so that one set of holes align with the securing lugs and insert the securing screws.
- 3 Adjust the height of the saddle to suit the rider and if necessary remove the backrest frame securing screws, reposition the backrest frame and replace the securing screws.
- 4 Ensure that all all nuts and bolts on the saddle assembly are tightened.

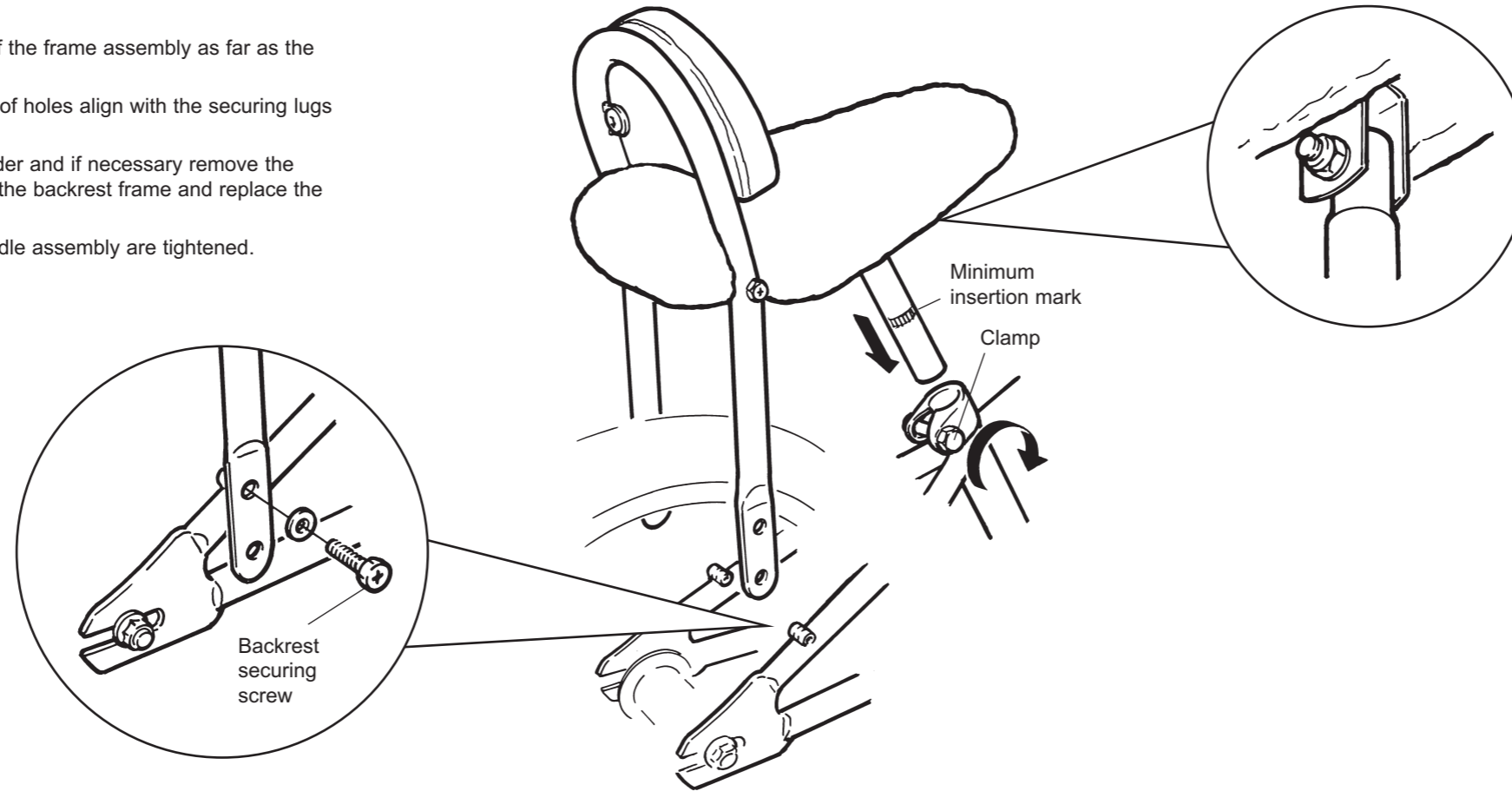

PROPER SEAT HEIGHT

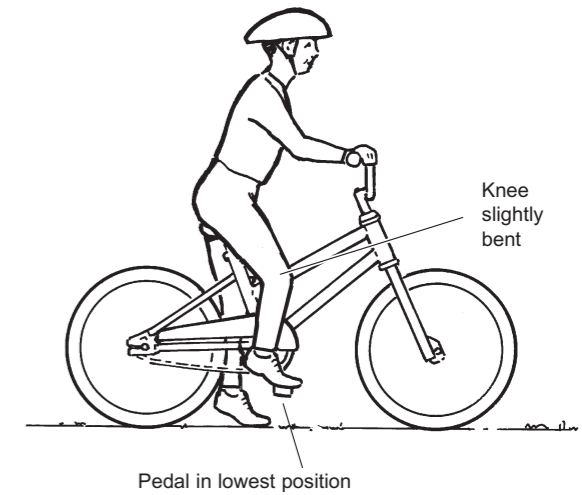

ADJUSTING THE BRAKE

- 1 On the front brake arm, loosen the anchor nut and bolt.
- 2 Squeeze the brake shoes together and using a pair of pliers, pull the inner brake cable tight.
- 3 Re-tighten the cable anchor nut and bolt.
- 4 Using the cable adjuster, adjust the brakes to give 1/16" (1.5mm) clearance between the brake blocks and the wheel rim
- 5 Tighten the cable adjuster lock nut.

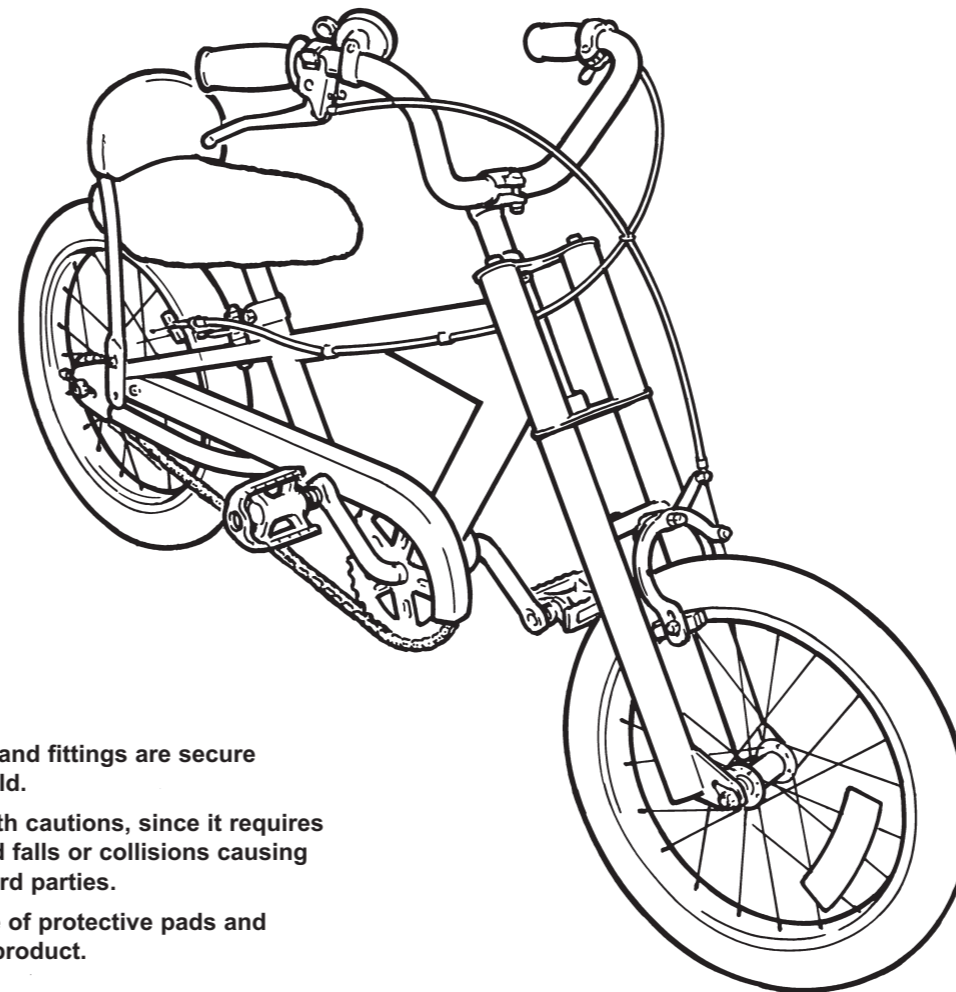
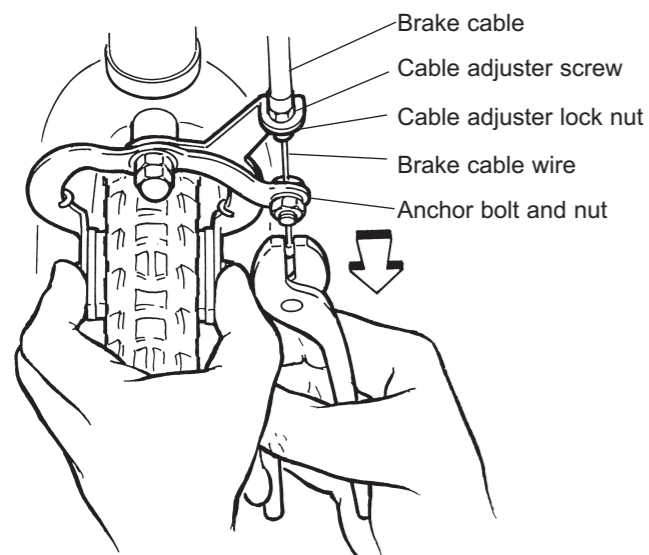

ASSEMBLED BIKE

Please check all screws and fittings are secure before giving to your child.

The toy shall be used with cautions, since it requires great skill, so as to avoid falls or collisions causing injury to the user and third parties.

MV recommends the use of protective pads and helmet when using this product.

A GUIDE TO SAFE CYCLING

1. We recommend this bike is for pavement use only.
 2. Do not ride at night. Visibility is often limited at dawn and dusk.
 3. Always give pedestrians right-of-way, and don't ride too close to them. Never park your bicycle where it can cause a nuisance.
 4. Avoid hazards that may cause you to lose control of your bicycle such as pot holes, uneven pavements and manhole covers.
 5. Leave plenty of room when passing parked vehicles and watch out for doors being opened in your path.
 6. Remember that braking distance should be increased in wet weather, and regular checks of brakes, steering and lighting should be made.
 7. Never carry passengers on your bicycle. Never carry packages in your hands while riding, or fix anything to your bicycle that could obstruct your visibility or control.
 8. Don't wear anything that restricts your hearing.
 9. Always ride with both hands on the handlebars.
 10. Don't wear very loose clothing, which could hang down and become caught in the wheels of your bicycle. Wear cuff bands or trouser clips to keep your trousers from getting caught in the chainwheel.
 11. We recommend that light-coloured or fluorescent clothing be worn which helps others to see you in daylight and poor light.
 12. Always wear proper safety equipment. We recommend a helmet, long-sleeve shirt, long trousers, shoes and elbow and knee pads. Gloves and eye protection also make good sense. Cover your handlebars, stem and top tube with safety pads for extra protection.
 13. Don't ride your bicycle if the chain cover is not attached.
- PLEASE REFER TO THE HIGHWAY CODE REGARDING RULES FOR CYCLISTS.**