

**2-4**  
YEARS

**TOOLS REQUIRED**



**CONTENTS**

- 1 Main frame
- 2 Forks
- 3 Handlebars
- 4 Bucket
- 5 Rear wheel cap (x2)
- 6 Rear wheel hub (x2)
- 7 Rear wheel (x2)
- 8 Axle
- 9 Front wheel assembly
- 10 Starlock fitting tool
- 11 Front plaque
- 12 Front mudguard
- 13 Handlebar grip (x2)
- 14 Saddle and pillar
- 15 Fork retaining bolt & nut (x2)
- 16 Saddle pillar bolt
- 17 Rear wheel spacer (x2)
- 18 Steering clamp
- 19 Steering clamp cover
- 20 Starlock
- 21 Parent pole

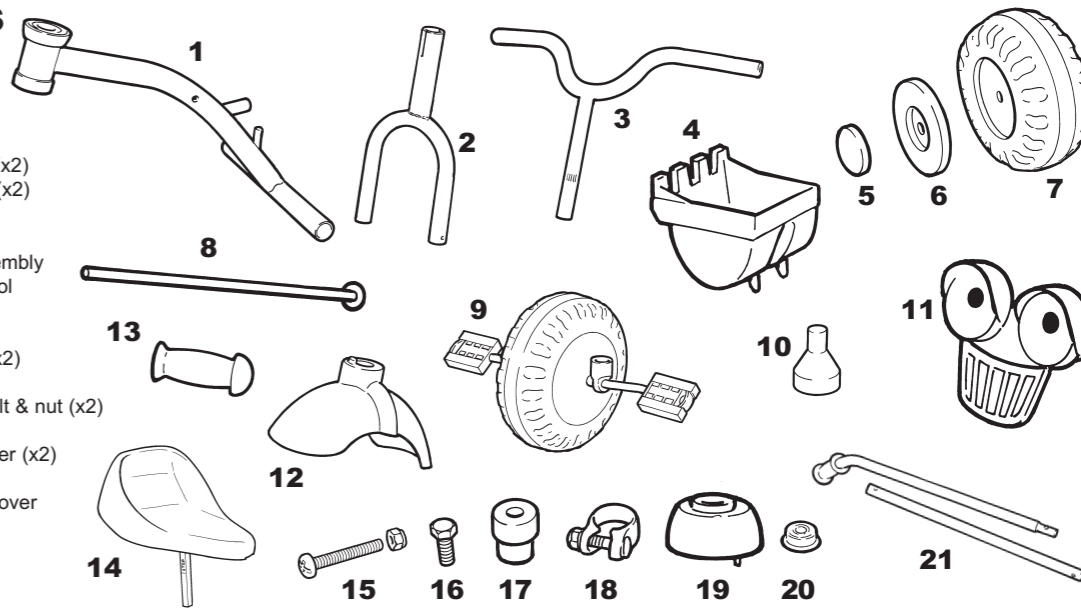

# Trike

**FRONT WHEEL**

1. Slide the mudguard onto the front forks.
  2. Push the front fork ends into the location cups on the front wheel assembly.
  3. Lock into position using the fork retaining nut and bolt.
- NOTE: Use your finger to ensure the captive nut in the location cup is retained.**
4. Push the stem through the main frame head, ensuring the steering lock tab is forward facing and locates in the groove in the frame head.

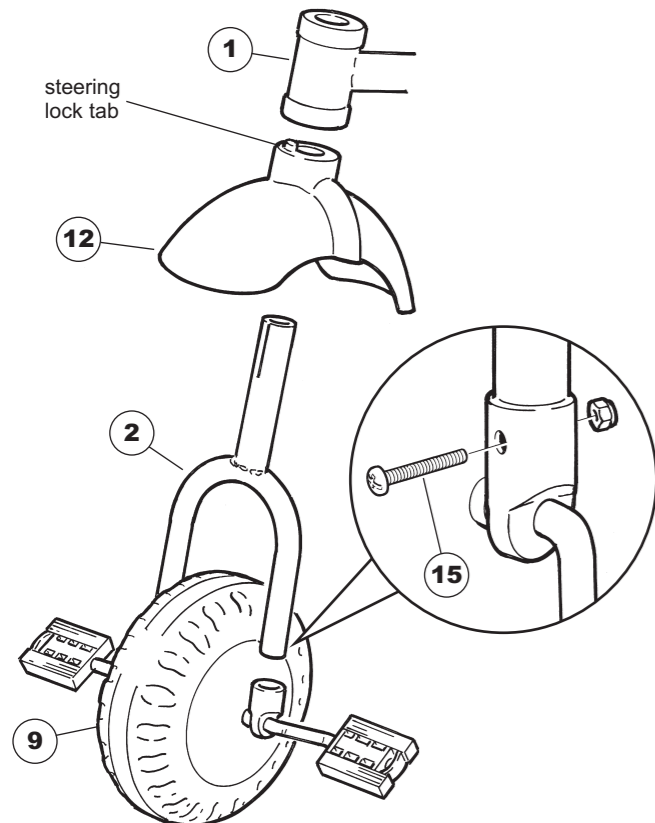

**Rear axle assembly**

1. Slide one of the rear wheel hubs onto the rear axle followed by one of the rear wheels, making sure that the 3 pegs on the insert locate in the holes in the wheel.
2. Slide a rear wheel spacer onto the axle with the thicker part against the wheel.
3. Slide the axle through the axle tube of the frame and push the bearing into the end of the tube.
4. Slide the second rear wheel spacer, thin end first, onto the axle and push it into the end of the axle tube.
5. Slide the second wheel onto the axle followed by the second rear wheel hub, making sure the 3 pegs locate correctly into the holes in the wheel.
6. Using the starlock fixing tool and a hammer knock the wheel securing starlock firmly onto the end of the axle.
7. Fit the two end covers in place making sure that the 4 locating latches are fitted into the holes in the wheel covers.
8. Please remove the starlock fixing tool after assembly.

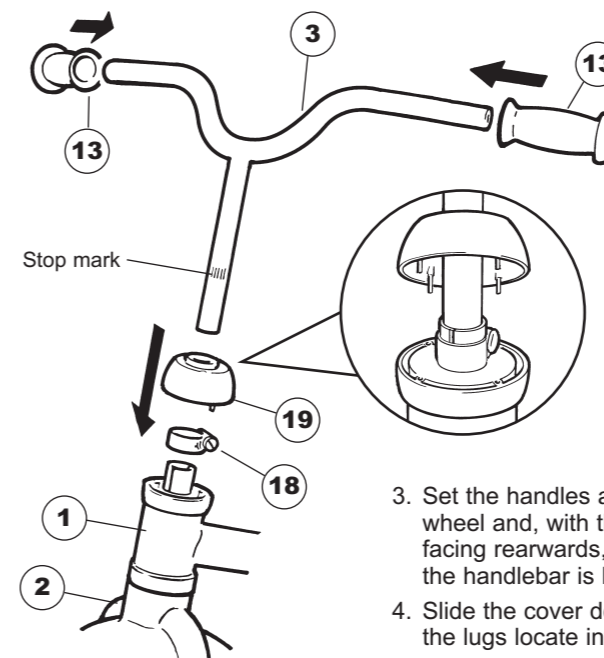
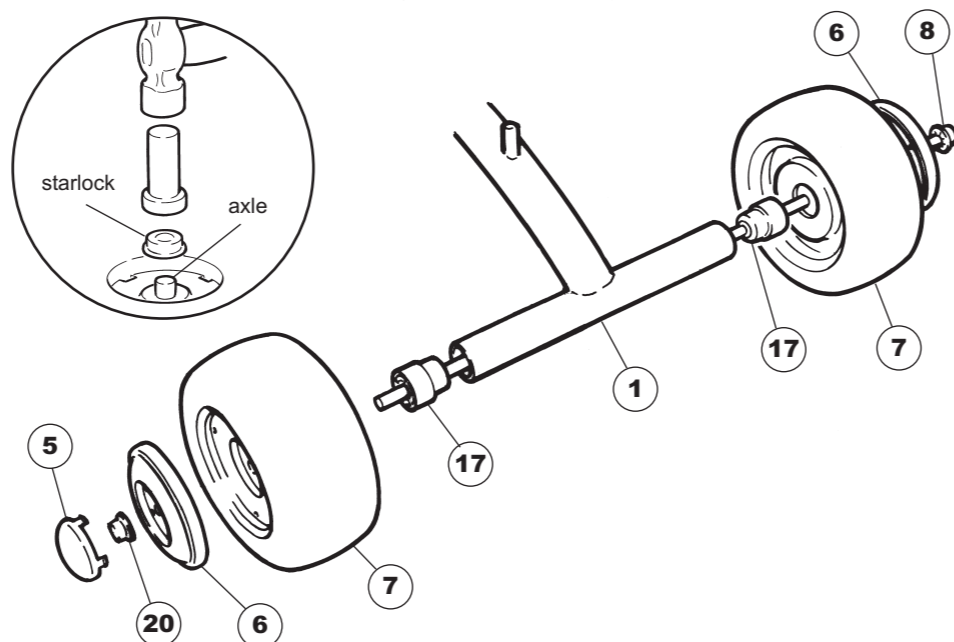

**HANDLEBARS**

1. Slide the handlebar grips onto the ends of the handlebars. Lubricate inside grips with washing-up liquid or detergent to help them slide on the handlebar ends.
2. Slide the clamp cover onto the handlebar stem and push the handlebar stem down into the top of the fork stem as far as the stop marks.
3. Set the handles at right angles to the front wheel and, with the clamp adjusting barrel facing rearwards, tighten the clamp and ensure the handlebar is locked into the forks.
4. Slide the cover down over the clamp ensuring the lugs locate into the slots in the frame head.

**SADDLE**

1. Screw the 13mm Hex Head bolt one or two turns into threaded hole in the side of the crossbar.
2. Push the saddle stem into the crossbar as far as the stop and fully tighten the bolt.

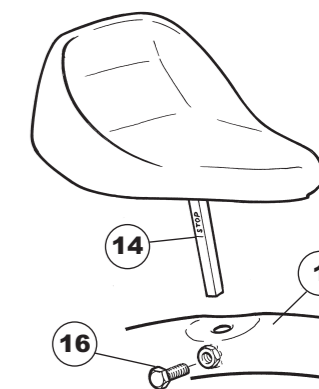

This trike is to be assembled by an adult. Check the contents and only remove the protective packaging from each item as and when it is to be fitted. Please keep the packaging until you have completely assembled the trike.

**Important owner's information**

Please read this before allowing your child to ride the trike.

**FOR YOUR CHILD'S SAFETY**

Recheck that all screws, nuts and bolts are firmly tightened. Make sure that your child is capable of riding this trike. Always supervise children when they are riding. It is important that they are never unattended. This trike is designed for a single rider, and should never be ridden by more than one child at a time. It's not recommended for riders over 20kg in weight.

**DO NOT STAND, SIT OR PUT EXCESSIVE PRESSURE ON THE BUCKET. WARNING! A PROTECTIVE HELMET SHOULD BE WORN WHEN CYCLING.**

**ATTACHING THE BUCKET**

1. Locate the bucket over the frame as illustrated.
2. Push the clips over the back axle whilst locating the bucket onto the frame bar.

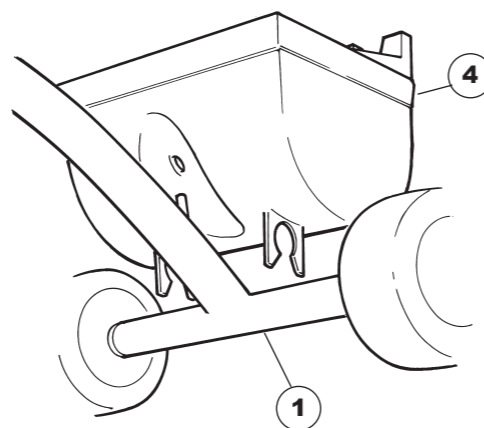

**ATTACHING THE FRONT PLATE**

1. Remove the screws and clamps on the front plate.
2. Position plate on the front of the handlebar, replace the clamps and replace the screws. Ensure the front plate is correctly positioned before tightening the screws.

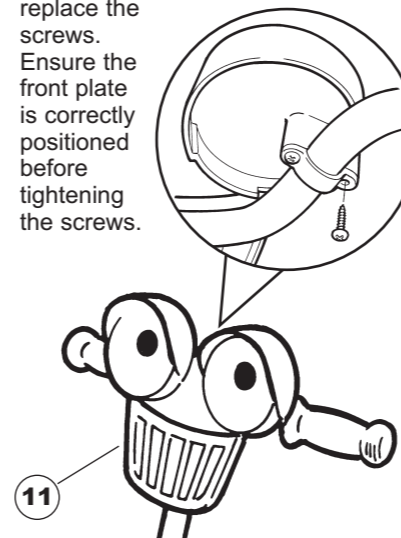

**ATTACHING THE PARENT POLE**

1. Push the two pieces of the parent pole together ensuring the spring clip locates into the retaining hole.
2. Push the parent pole into the frame bracket ensuring the spring clip locates into the retaining hole.
3. When the parent pole is not required, remove the pole by pressing the spring clip and pulling out. Close the end cap.

Please check all screws and fittings are secure before giving to your child.

**WARNING:** The trike should never be used with the parent pole only partially assembled.

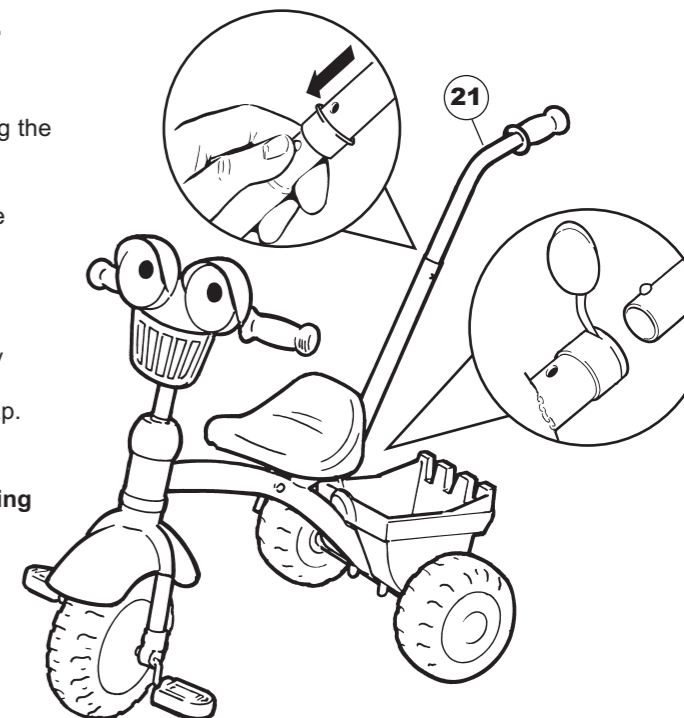

DISTRIBUTED BY



MV SPORTS & LEISURE LTD  
35 Tameside Drive  
Castle Bromwich • Birmingham  
B35 7AG • UK  
Email: info@mvsports.com  
www.mvsports.com

Please retain this leaflet for reference to the manufacturer. Made in Taiwan to European Safety Standards.



The CE mark denotes compliance with the standards laid down by the EC (European Community).

**CUSTOMER HELPLINE (UK ONLY) 0870 8404255**

We make every effort to ensure that this product reaches you in satisfactory condition.

However if you have any queries, need assistance, or find this product defective, please call our Customer Helpline.