

3+
YEARS

Triscooter

This scooter is to be assembled by an adult.

Check the contents and only remove the protective packaging from each item as and when it is to be fitted.

Please keep the packaging until you have completely assembled the scooter.

WARNING: Not suitable for children under 36 months due to small parts.

TOOLS REQUIRED

NOT SUPPLIED

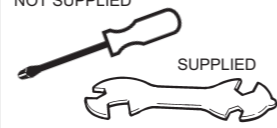

CONTENTS:

1. Frame and footplate assembly
2. Front fork and wheel assembly
3. Handlebars & front plate assembly
4. Rear axle
5. Rear wheels (2)
6. Clamp cover
7. Clamp assembly
8. Large steel washers (2)
9. Plastic spacers (2)
10. Medium steel washers (3)
11. Small steel washers (1)
12. Spring washers (1)
13. Nylon nut
14. Spanner (2)

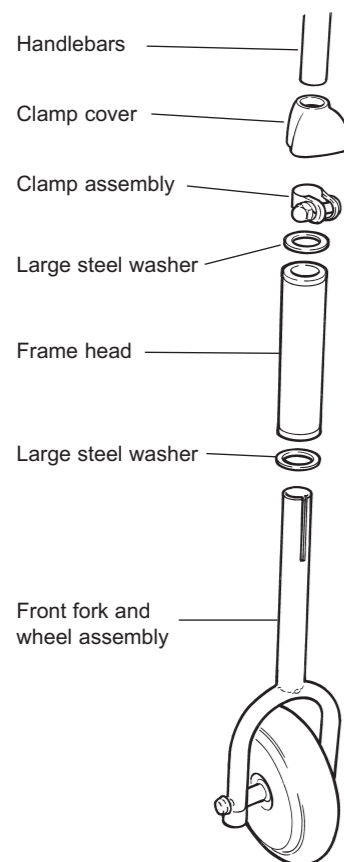
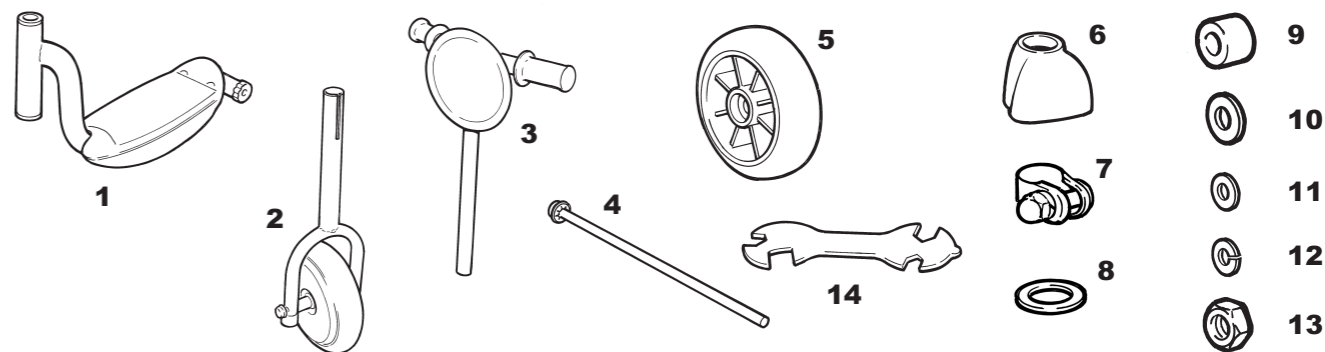

HANDLEBAR AND FRONT WHEEL ASSEMBLY

Remove transit protectors from fork stem and handlebar stem before assembly

1. Slide one of the two large steel washers onto the fork stem.
2. Insert the front fork stem through the frame head with the slot in the stem facing rearwards.
3. Place the second large steel washer onto the end of the fork stem followed by the clamp assembly with the clamp bolt at the back.
4. Partly tighten the clamp until it lightly nips the end of the fork stem.
5. Slide the clamp cover onto the handlebar stem.
6. Insert the handlebar stem into the fork stem to the desired position, ensuring that the minimum insertion mark of the handlebar stem is not visible.
7. Tighten the clamp bolt using the appropriate size spanner.

REAR WHEELS

1. Slide a medium steel washer onto the free end of the axle.
2. Slide one of the wheels, spoke side first, onto the axle followed by a second medium steel washer and a plastic spacer.
3. Insert the axle through the rear bearings.
4. Slide a second plastic spacer onto the axle followed by the medium steel washer and the second rear wheel, flat side first.
5. Fit small steel washer and spring washer over threaded section of axle bolt and screw on nut. Tighten nut using spanner.

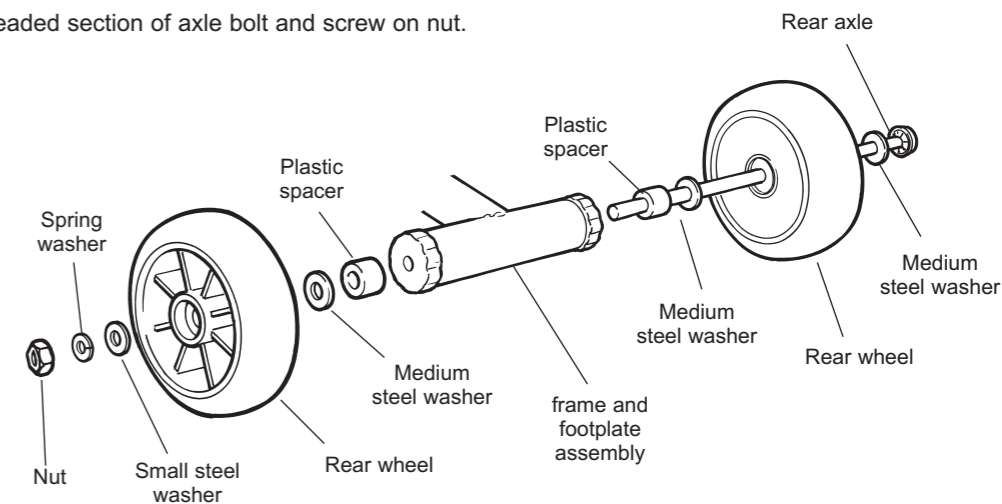

SAFETY ADVICE

This is a three wheel self propelled scooter designed for a single rider only.

Not for children with a body weight of more than 20kg.

It is not intended or equipped for road use, off road use, racing, jumping, stunt riding or use with any motorised device.

NOTE:

It should never be ridden by more than one person at a time. Never ride at night, obey all traffic and pedestrian regulations, and give right of way to pedestrians.

Care should be taken when riding on wet pavements as braking action and wheel traction may be reduced.

Never leave your scooter unlocked and unattended.



The CE mark denotes compliance with the standards laid down by the EC (European Community).

FOR YOUR CHILD'S SAFETY

Recheck that all screws, nuts and bolts are firmly tightened.

Make sure that your child is capable of riding this scooter.

Do not allow your child to ride unsupervised.

SCOPE AND LIMITED WARRANTY

This warranty does not cover damage or loss from accidents, normal wear, improper assembly or adjustment, jumping, stunt riding, racing or competition, abuse, neglect or when used with any motorised device.

Please retain this leaflet for reference to the manufacturer.

Made in China to European Safety Standards.

DISTRIBUTED BY



MV SPORTS & LEISURE LTD
35 Tameside Drive • Castle Bromwich
Birmingham B35 7AG • UK
Email: info@mvsports.com
www.mvsports.com

ASSEMBLED SCOOTER

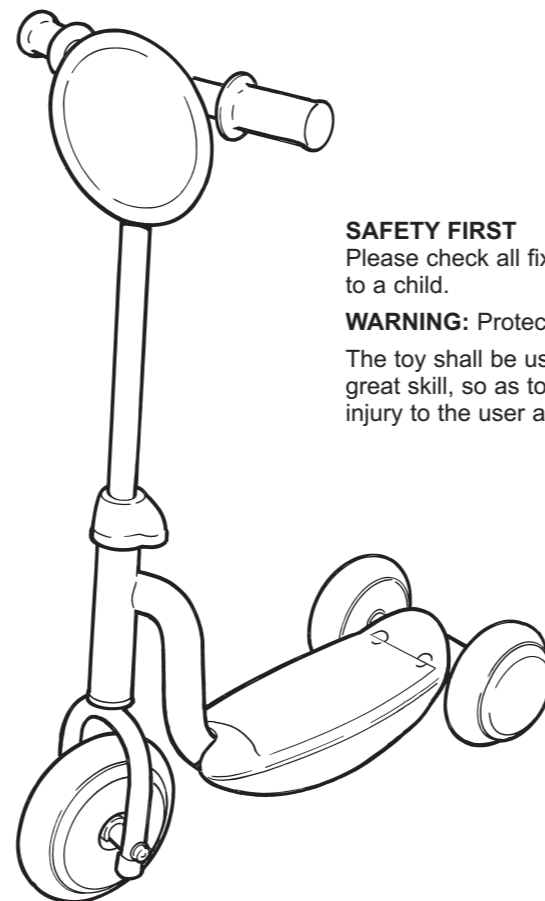

SAFETY FIRST

Please check all fixings are secure before handing to a child.

WARNING: Protective equipment should be worn.

The toy shall be used with caution, since it requires great skill, so as to avoid falls or collisions causing injury to the user and third parties.

A GUIDE TO SAFE CYCLING & SCOOTERING

1. We recommend this scooter is for pavement use only.
2. Do not ride at night. Visibility is often limited at dawn and dusk.
3. Always give pedestrians right-of-way, and don't ride too close to them. Never park your bicycle or scooter where it can cause a nuisance.
4. Avoid hazards that may cause you to lose control of your bicycle or scooter such as pot holes, uneven pavements and manhole covers.
5. Leave plenty of room when passing parked vehicles and watch out for doors being opened in your path.
6. Remember that braking distance should be increased in wet weather, and regular checks of brakes, steering and lighting should be made.
7. Never carry passengers on your bicycle or scooter. Never carry packages in your hands while riding, or fix anything to your bicycle or scooter that could obstruct your visibility or control.
8. Don't wear anything that restricts your hearing.
9. Always ride with both hands on the handlebars.
10. Don't wear very loose clothing, which could hang down and become caught in the wheels. Wear cuff bands or trouser clips to keep your trousers from getting caught in the chainwheel.
11. We recommend that light-coloured or fluorescent clothing be worn which helps others to see you in daylight and poor light.
12. Always wear proper safety equipment. We recommend a helmet, long-sleeved shirt, long trousers, shoes, elbow pads and knee pads. Gloves and eye protection also make good sense. Cover your handlebars, stem and top tube with safety pads for extra protection.
13. Don't ride your bicycle if the chain cover is not attached

Please refer to the Highway Code regarding rules for cyclists

CUSTOMER HELPLINE (UK ONLY) 0870 8404255

We make every effort to ensure that this product reaches you in satisfactory condition.

However if you have any queries, need assistance, or find this product defective, please call our Customer Helpline.