

12" Bicycle

Important owner's information

Please read this before allowing your child to ride the bicycle.

CORRECT BICYCLE SIZE

Make sure the bicycle you have bought is the correct size for the child. The minimum crotch measurement of the rider, with feet flat on the ground, should be 1" (25mm) more than the height of the bike.

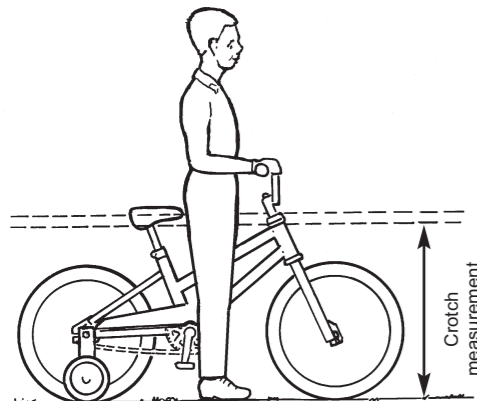

BICYCLE SET-UP

It is essential that, before moving off, the rider is comfortably seated on the bicycle and not stretching forward to reach the handlebars.

Re-check the instructions given for the installation of the saddle.

FOR YOUR CHILD'S SAFETY

Recheck that all screws, nuts and bolts are firmly tightened. Make sure that your child is capable of riding this bicycle. Do not allow your child to ride without supervision.

BASIC MAINTENANCE

To adjust the tension of the chain drive, loosen the two rear wheel retaining nuts and move the back wheel either forwards or backwards to adjust tension. Re-tighten nuts once correct tension is achieved.

Brake blocks must be checked by an adult at regular intervals. It is recommended that the brake blocks are replaced if they become less than 3mm on the shortest side.

Lubricate moving parts with light machine oil at regular intervals or when necessary.

Any wear on tyres must be checked by an adult. Please note helpline number for replacement parts.

RECOMMENDED TORQUE TOLERANCES

| | |
|-----------------|-------|
| Handlebar clamp | 15 nm |
| Seat Post | 15 nm |
| Wheels | 20 nm |

Please retain this leaflet for reference to the manufacturer.
Made in China to European Safety Standards.

Conforms to ISO8098

CUSTOMER HELPLINE

We make every effort to ensure that this product reaches you in satisfactory condition.

However if you have any queries, need assistance, or find this product defective, please call our Customer Helpline:

0870 8404255 (UK ONLY)

DISTRIBUTED BY



MV SPORTS & LEISURE LTD

35 Tameside Drive • Castle Bromwich • Birmingham • B35 7AG • UK
Email: info@mvsports.com • www.mvsports.com

This bicycle is to be assembled by an adult

Check the contents and only remove the protective packaging from each item as and when it is to be fitted

Please keep the packaging until you have completely assembled the bicycle.

TRANSIT PROTECTORS

Remove frame protectors and dispose of safely.

Transit protector

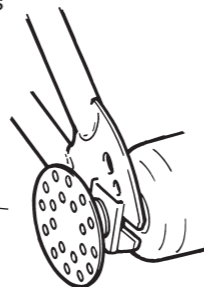

FRONT FORK ASSEMBLY

- 1 Push the 2 head bearing cups firmly into the top and bottom of the head tube.
- 2 Slide head bearing spacer onto front fork stem.
- 3 Insert front fork stem through the frame head bearings with the steering lock tab facing forwards. Ensure the steering lock tab engages into the steering lock.
- 4 Slide the head bearing insert and the handlebar clamp onto the front fork stem with clamping at the back.
- 5 DO NOT TIGHTEN THE CLAMP AT THIS STAGE

FITTING THE BRAKE CALLIPER

1. Remove the nut, washer and saddle washer from the brake calliper assembly.
2. Insert the calliper assembly bolt through the hole in frame fork tube.
3. Replace saddle washer, washer and nut and tighten.
4. Adjust brake if necessary. (see "adjusting the brake" overleaf)

TOOLS REQUIRED

NOT SUPPLIED

Spanner sizes:
10mm for brakes
13mm for saddle
14mm for stabilisers
15mm for pedals

Screwdriver

Pliers



CONTENTS:

1. Frame assembly
2. Front wheel
3. Front forks
4. Handlebar assembly
5. Saddle and saddle pillar assembly
6. Stabilizer arm and wheel assembly (x2)
7. Brake assembly
8. Pedals (x2)
9. Handlebar clamp
10. Head bearing insert
11. Head bearing cup (x2)
12. Head bearing spacer

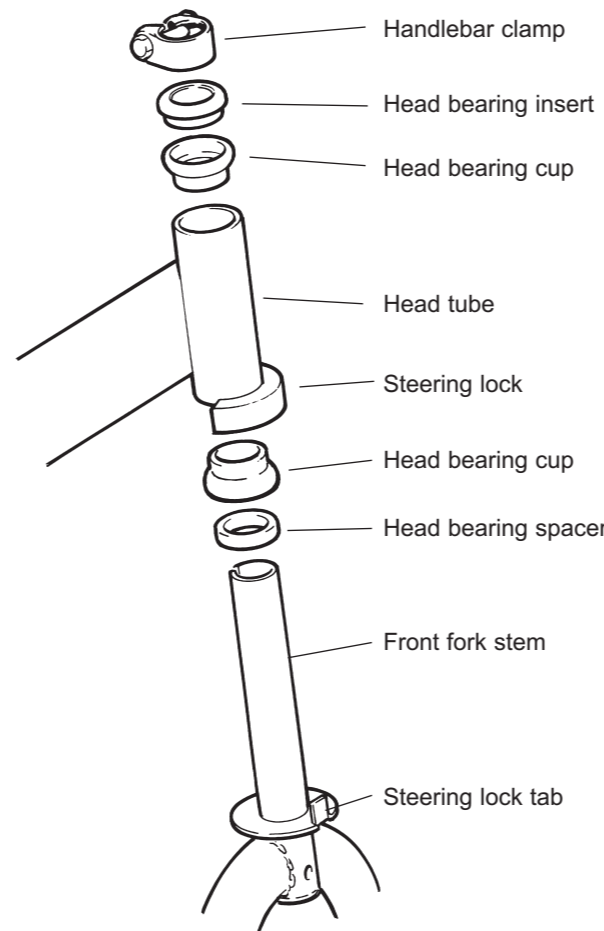
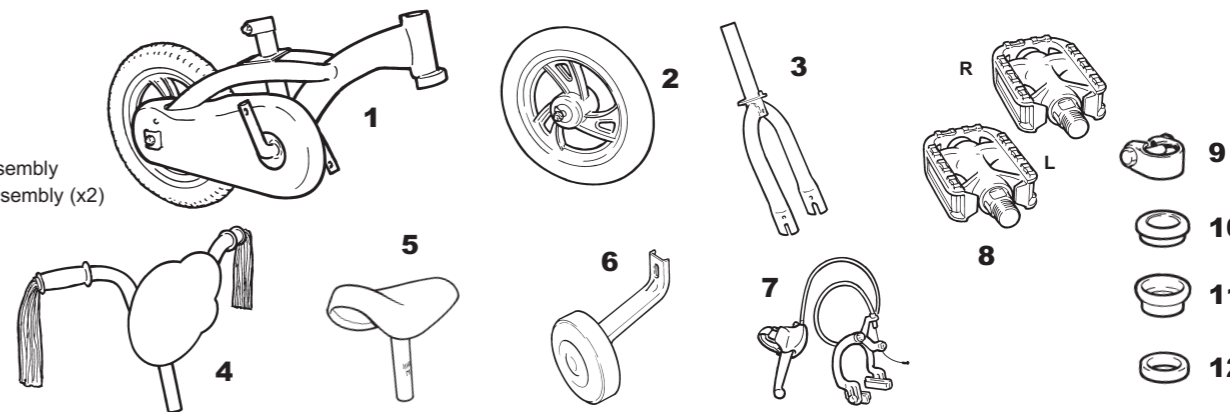

FITTING THE HANDLEBARS

1. Slide the handlebars into the fork stem at least as far as the minimum insertion mark.
2. Align the handlebars with the front wheel and tighten the handlebar clamp.
3. Slide the clamp cover down over the clamp.

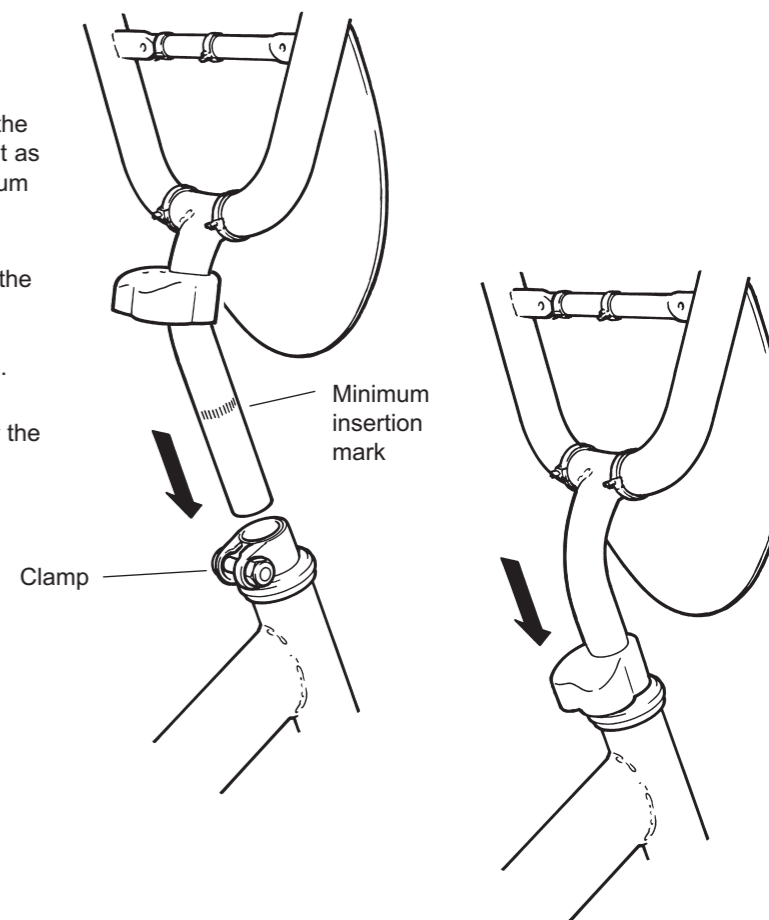

FITTING THE BRAKE LEVER

1. Position the brake lever clamp on the right hand side of the handlebar.
2. Adjust the clamp to achieve the proper angle of the lever.
3. Insert the bolt and washer through the clamp and secure using nut.
4. The small hexagonal part of the nut fits into the hole in the brake lever clamp.
5. Ensure the brake lever does not swivel on the handlebar tube.

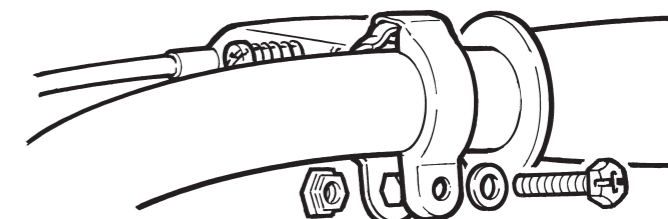

FRONT WHEEL

Please ensure you have fitted the mudguard before fitting the front wheel

1. Loosen the front wheel nuts sufficiently to allow the tabbed locating washers to fit outside the fork end.
2. Insert the front wheel into the front forks, sliding the wheelspindle into the slots in the fork end.
3. Ensure that the locating washer tabs are inserted into the holes in the fork end.
4. Check that the wheel rim is central between the forks and tighten the wheel nuts.

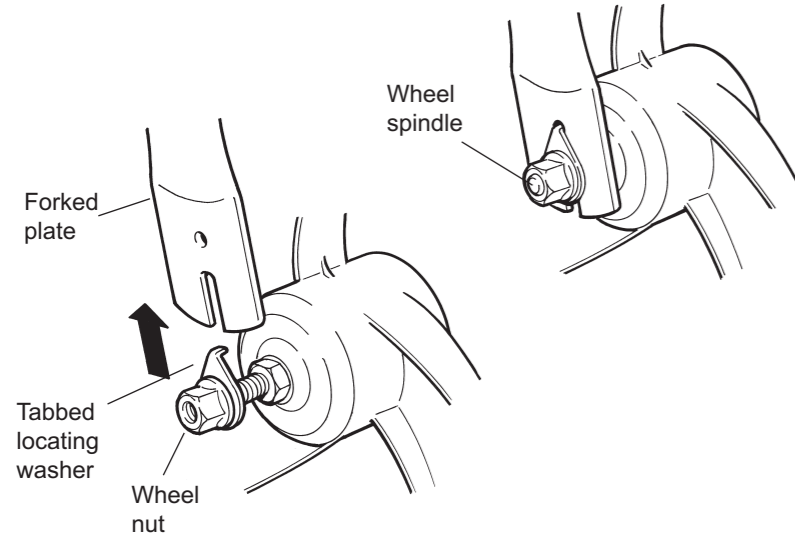

FITTING THE PEDALS

NOTE: The pedals are identified as right hand or left hand by an 'R' or 'L' on the spindle end.

1. Screw the pedal marked 'R' clockwise into the right hand chain wheel crank (side with chainguard) and tighten securely.
2. Screw the pedal marked 'L' anti-clockwise into left hand crank and tighten securely.

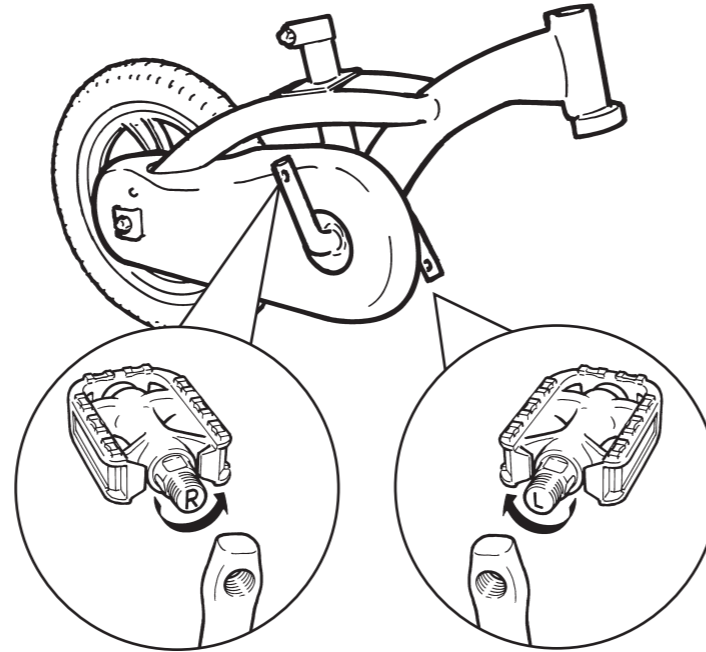

FITTING THE SADDLE

1. Push the saddle pillar into the down tube at least as far as the Minimum insertion mark.
2. Align the saddle with the bike frame and tighten the clamp with a spanner.

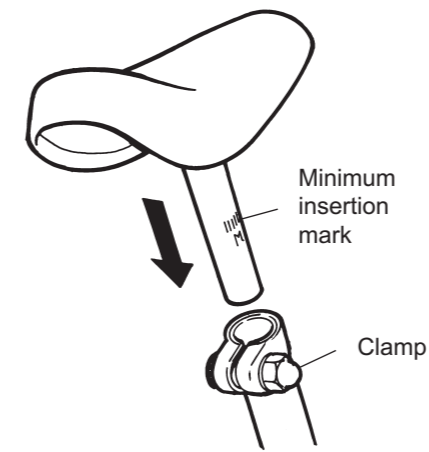

PROPER SEAT HEIGHT

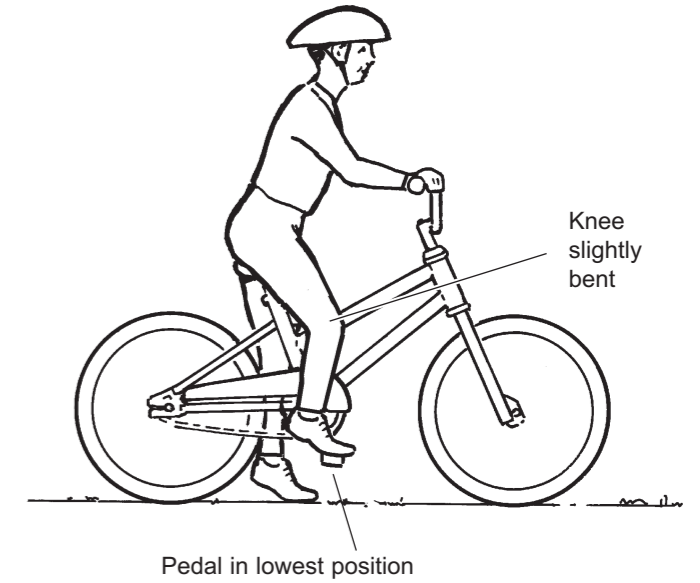

FITTING THE STABILIZERS

1. Remove the nut and washer from the rear axle frame assembly leaving the stabilizer frame bracket in position.
2. Slide the stabilizer over the threaded axle spindle end.
3. Replace washer and nut and tighten.
4. To adjust the stabilizer wheel height, loose the nut, slide the stabilizer up or down to adjust the wheel height and retighten the nut.

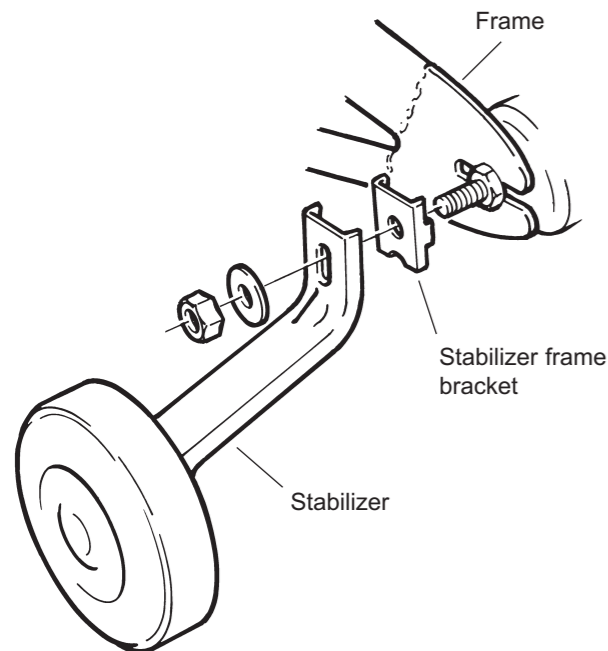

ADJUSTING THE BRAKE

1. On the front brake arm, loosen the anchor nut and bolt.
2. Squeeze the brake shoes together and using a pair of pliers, pull the inner brake cable tight.
3. Re-tighten the cable anchor nut and bolt.
4. Using the cable adjuster, adjust the brakes to give 1/16" clearance between the brake blocks and the wheel rim
5. Tighten the cable adjuster lock nut.
6. Check the brake blocks make contact with the wheel rim and not the tyre.

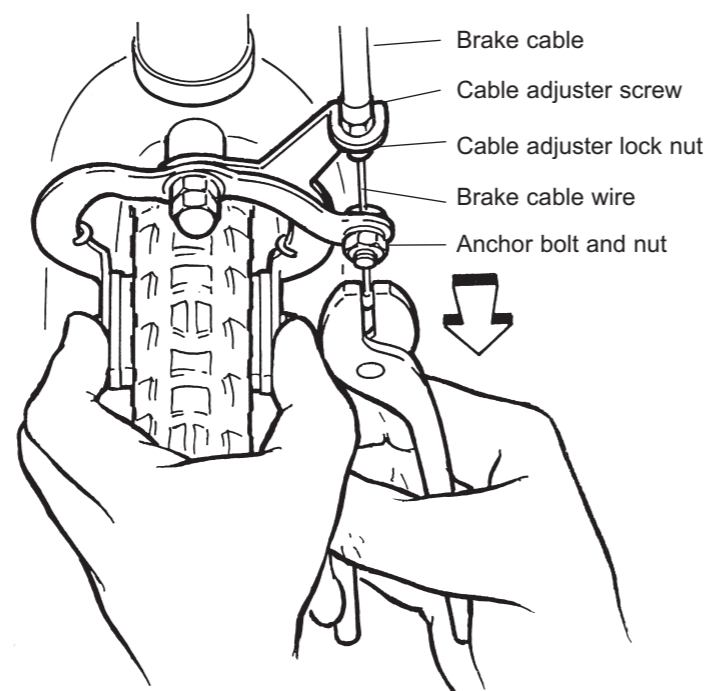

ASSEMBLED BIKE

Please check all screws and fittings are secure before giving to your child.

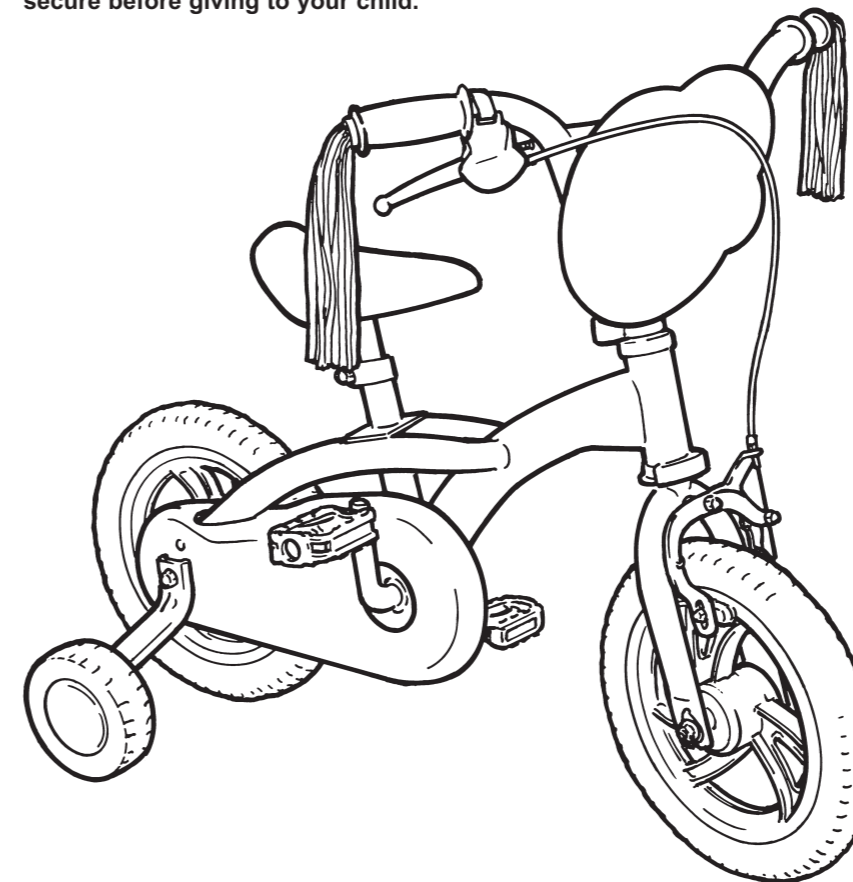

A GUIDE TO SAFE CYCLING

1. We recommend this bike is for pavement use only.
2. Do not ride at night. Visibility is often limited at dawn and dusk.
3. Always give pedestrians right-of-way, and don't ride to close to them. Never park your bicycle where it can cause a nuisance.
4. Avoid hazards that may cause you to lose control of your bicycle such as pot holes, uneven pavements and manhole covers.
5. Leave plenty of room when passing parked vehicles and watch out for doors being opened in your path.
6. Remember that braking distance should be increased in wet weather, and regular checks of brakes, steering and lighting should be made.
7. Never carry passengers on your bicycle. Never carry packages in your hands while riding, or fix anything to your bicycle that could obstruct your visibility or control.
8. Don't wear anything that restricts your hearing.
9. Always ride with both hands on the handlebars.
10. Don't wear very loose clothing, which could hang down and become caught in the wheels of your bicycle. Wear cuff bands or trouser clips to keep your trousers from getting caught in the chainwheel.
11. We recommend that light-coloured or fluorescent clothing be worn which helps others to see you in daylight and poor light.
12. Always wear proper safety equipment. We recommend a helmet, long-sleeve shirt, long trousers, shoes and elbow and knee pads. Gloves and eye protection also make good sense. Cover your handlebars, stem and top tube with safety pads for extra protection.
13. Don't ride your bicycle if the chain cover is not attached.

PLEASE REFER TO THE HIGHWAY CODE REGARDING RULES FOR CYCLISTS.