

10" Scooter

This scooter is to be assembled by an adult.

Check the contents and only remove the protective packaging from each item as and when it is to be fitted.

Please keep the packaging until you have completely assembled the scooter.

WARNING: Not suitable for children under 36 months due to small parts.

CONTENTS:

- 1 Frame and platform
- 2 Wheels (x2)
- 3 Front fork
- 4 Handle bar assembly
- 5 Clamp cover
- 6 Frame head clamp
- 7 Plastic washer (x2)
- 8 Plastic head bearing insert (x2)
- 9 Plaques
- 10 Plaque ties (x3)
- 11 Spanner

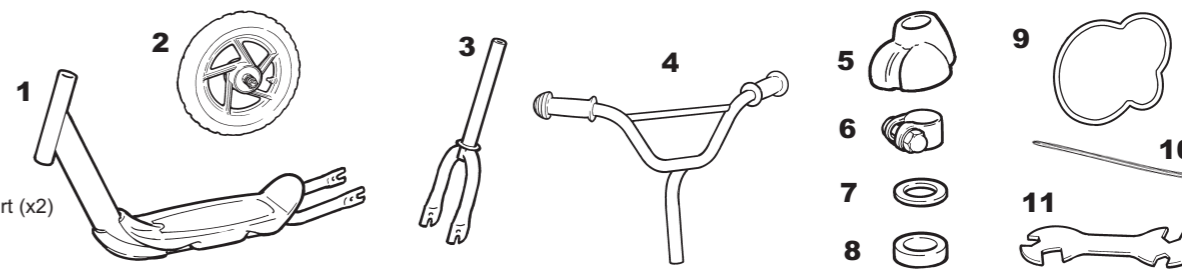

TRANSIT PROTECTORS

Remove frame protectors (A) and nut (Bx2) and dispose of safely.

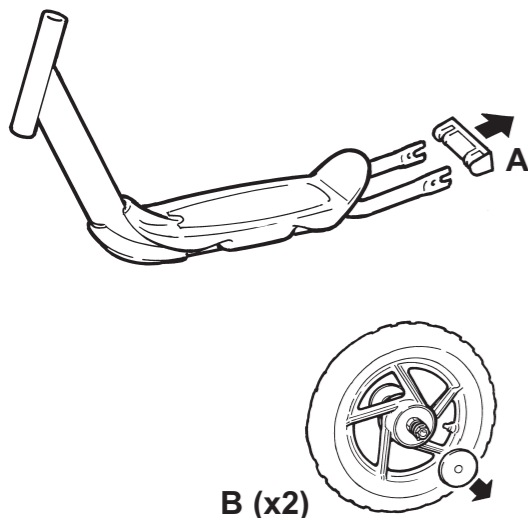

FITTING FRONT WHEEL

- 1 Loosen the wheel nuts sufficiently to allow the tabbed locating washers to fit outside the front forks.
- 2 Insert the wheel into the forks, sliding the wheel spindle into the slots in the forks.
- 3 Ensure that the tab washers are inserted into the locating holes in the front forks.
- 4 Check that the wheel rim is central between the forks and tighten the wheel nuts.

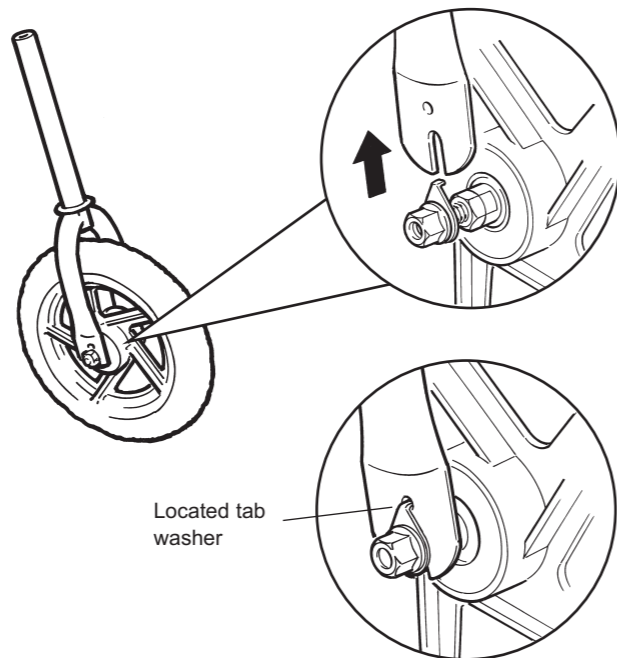

FRONT FORKS

- 1 Push the 2 head bearing inserts firmly into the top and bottom of the head tube.
- 2 Slide the first plastic washer onto front fork stem.
- 3 Insert fork stem through the frame head tube with the stem facing rearwards.
- 4 Slide the second plastic washer and the clamp assembly onto the fork stem with clamping bolt at the back.

NOTE: The top of the clamp assembly should be flush with the end of the fork stem. If not, check that the head bearing inserts are pushed fully into the head tube.

- 5 Partly tighten the clamp until it nips the end of the fork stem.

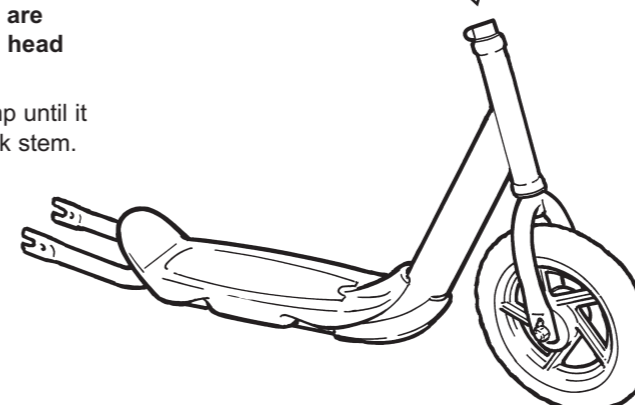
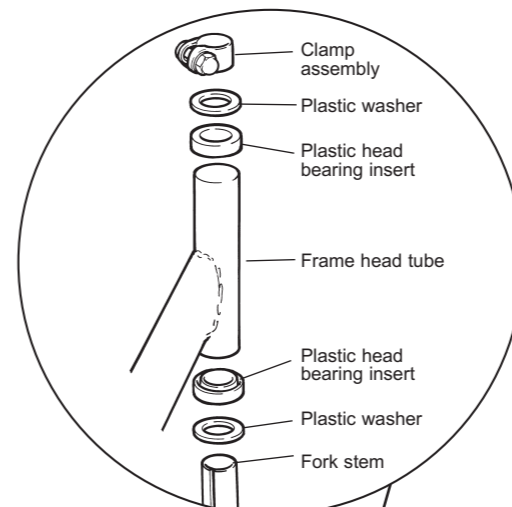

HANDLEBARS

- 1 Slide the clamp cover onto the handlebar stem.
- 2 Insert the handlebar stem into the fork stem to the desired position, ensuring that the minimum insertion mark is not visible.

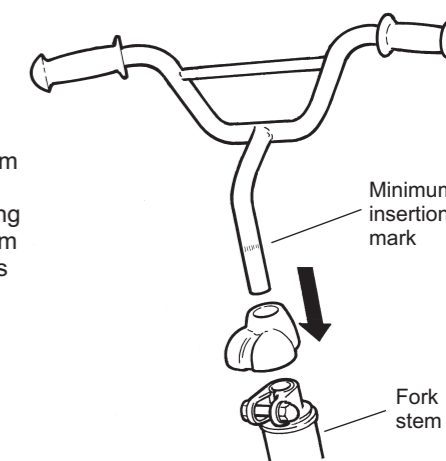

- 3 Tighten the clamp bolt using the spanner supplied. Ensure that the handlebars are clamped securely to the forks and front wheel. Slide the clamp cover down over the frame head clamp.

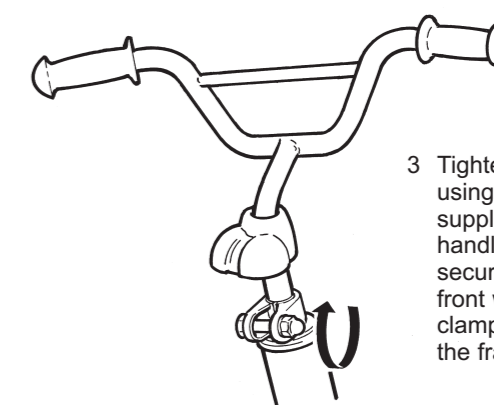

SAFETY ADVICE

This is a two wheel self propelled scooter designed for a single rider only.

It is not suitable for a child of more than 20 kgs.

It is not intended or equipped for road use, off road use, racing, jumping, stunt riding or use with any motorised device.

NOTE:

It should never be ridden by more than one person at a time. Never ride at night, obey all traffic and pedestrian regulations, and give right of way to pedestrians.

Care should be taken when riding on wet pavements as braking action and wheel traction may be reduced.

Never leave your scooter unlocked and unattended.

FOR YOUR CHILD'S SAFETY

Recheck that all screws, nuts and bolts are firmly tightened.

Make sure that your child is capable of riding this scooter.

Do not allow your child to ride unsupervised.

SCOPE AND LIMITED WARRANTY

This warranty does not cover damage or loss from accidents, normal wear, improper assembly or adjustment, jumping, stunt riding, racing or competition, abuse, neglect or when used with any motorised device.

DISTRIBUTED BY



Please retain this leaflet for reference to the manufacturer. Carefully made in China to European Safety Standards.



The CE mark denotes compliance with the standards laid down by the EC (European Community).

MV SPORTS & LEISURE LTD
35 Tameside Drive
Castle Bromwich • Birmingham
B35 7AG • UK
Email: info@mvsports.co.uk

ATTACHING THE FRONT PLATE - Disregard this section if the front plate is already attached.

- 1 Position plate on the front of the handlebar and fix with plastic ties.
- 2 Cut close to the edge once locked into position.

NOTE: There are 3 fixing positions, top left, top right and centre bottom.

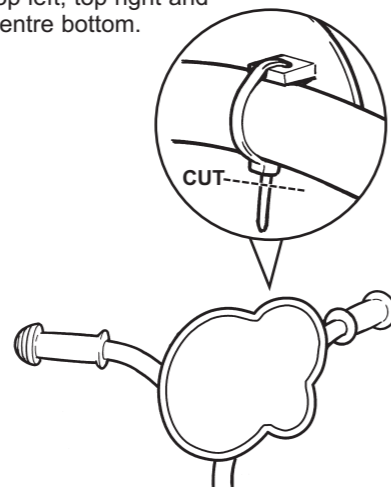

FITTING REAR WHEEL

- 1 Loosen the wheel nuts sufficiently to allow the tabbed locating washers to fit outside the rear forks.
- 2 Insert the wheel into the forks, sliding the wheel spindle into the slots in the forks.
- 3 Ensure that the tab washers are inserted into the locating holes in the rear forks.
- 4 Check that the wheel rim is central between the forks and tighten the wheel nuts.

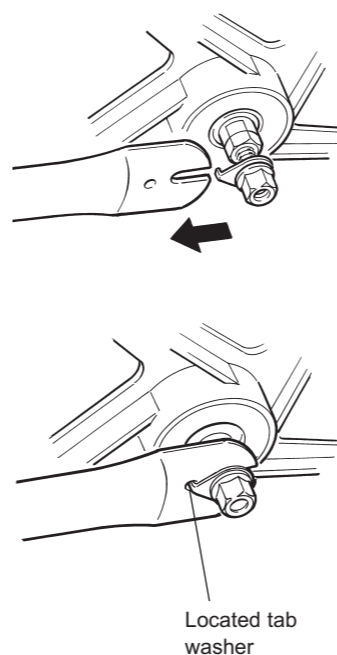

ASSEMBLED SCOOTER

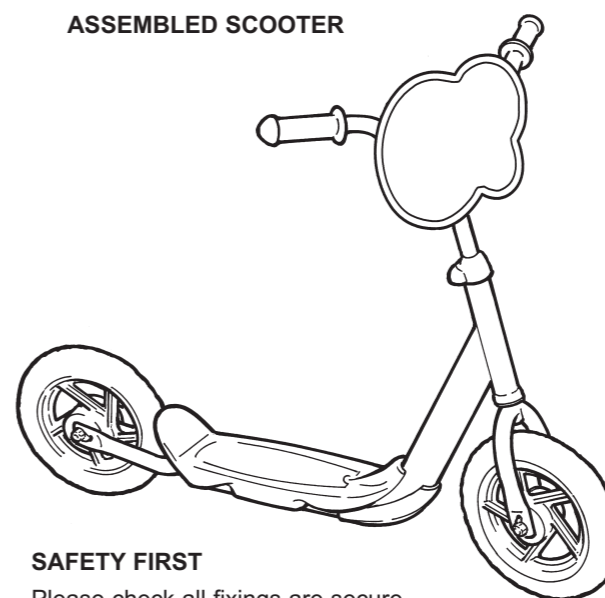

SAFETY FIRST

Please check all fixings are secure before handing to a child.

This toy should be used with caution, since it requires great skill, so as to avoid falls or collisions causing injury to the user and third parties.

A GUIDE TO SAFE CYCLING & SCOOTERING

- 1 We recommend this scooter is for pavement use only.
- 2 Do not ride at night. Visibility is often limited at dawn and dusk.
- 3 Always give pedestrians right-of-way, and don't ride too close to them. Never park your bicycle or scooter where it can cause a nuisance.
- 4 Avoid hazards that may cause you to lose control of you bicycle or scooter such as pot holes, uneven pavements and manhole covers.
- 5 Leave plenty of room when passing parked vehicles and watch out for doors being opened in your path.
- 6 Remember that braking distance should be increased in wet weather, and regular checks of brakes, steering and lighting should be made.
- 7 Never carry passengers on your bicycle or scooter. Never carry packages in your hands while riding, or fix anything to your bicycle or scooter that could obstruct your visibility or control.
- 8 Don't wear anything that restricts your hearing.
- 9 Always ride with both hands on the handlebars.
- 10 Don't wear very loose clothing, which could hang down and become caught in the wheels. Wear cuff bands or trouser clips to keep your trousers from getting caught in the chainwheel.
- 11 We recommend that light-coloured or fluorescent clothing be worn which helps others to see you in daylight and poor light.
- 12 Always wear proper safety equipment. We recommend a helmet, long-sleeved shirt, long trousers, shoes, elbow pads and knee pads. Gloves and eye protection also make good sense. Cover your handlebars, stem and top tube with safety pads for extra protection.
- 13 Don't ride your bicycle if the chain cover is not attached

CUSTOMER HELPLINE (UK ONLY) 0870 8404255

We make every effort to ensure that this product reaches you in satisfactory condition.

However if you have any queries, need assistance, or find this product defective, please call our Customer Helpline.